

FEATURES

- RoHS compliant
- Single 5V supply
- Thermal shutdown protection
- EIA-485 and CCITT V.28 compatible
- Dual differential driver and receiver
- Driver tri-state outputs active high enable
- Low Profile 24 pin DIL package style
- 1kVrms Isolation

DESCRIPTION

The NM485DC is an electrically isolated dual differential driver and receiver designed for balanced multipoint bus transmission at rates up to 1.25Mbps per second. The device provides two receive channels and two driver channels. The two driver channels have an active high enable. No external components are needed and a single 5V input supply powers all functions either side of the isolation boundary. The driver outputs provide limiting for positive and negative currents and thermal shutdown protection from line fault conditions on the transmission bus line. The receiver outputs will always be high if the receiver inputs are open. The isolation voltage between input and output is 1000Vrms, the devices are supplied in a low profile 24 pin DIL plastic package.



ELECTRICAL CHARACTERISTICS

Parameter	Test conditions	Min.	Typ.	Max.	Units
Supply voltage, V_{CC}		4.75	5.0	5.25	V
High level input voltage, V_{IH}	Dx ENABLE and D inputs	2.8			V
Low level input voltage, V_{IL}				0.8	V
Common mode output voltage, V_{OC}		-7.0		12	V
High level output current, I_{OH}	Driver			-60	mA
Low level output current, I_{OL}				60	mA
Common mode input voltage, V_{IC}	Receiver			± 12	V
Differential input voltage, V_{ID}				± 12	V
High level output current, I_{OH}				-5.0	mA
Low level output current, I_{OL}				25	mA

EACH RECEIVER ELECTRICAL CHARACTERISTICS

Parameter	Test conditions	Min.	Typ.	Max.	Units
High threshold differential input, V_{TH}	$V_{O}=2.7V, I_{O}=-0.4mA$			0.2	V
Low threshold differential input, V_{TL}	$V_{O}=0.5V, I_{O}=16mA$	-0.2			V
Input hysteresis, ΔV_{T}			50		mV
High level output voltage, V_{OH}	$V_{ID}=200mV, I_{OH}=-5.0mA$	2.7			V
Low level output voltage, V_{OL}	$V_{ID}=200mV, I_{OL}=25mA$			0.8	V
Line input current, I_{I}	Other input at 0V, $V_{I}=12V$			1.0	mA
	Other input at 0V, $V_{I}=-12V$			-0.8	mA
Short circuit output current, I_{OS}				-15	mA
Input resistance, R_{I}		12			K Ω

RECEIVER SWITCHING CHARACTERISTICS

Parameter	Test conditions	Min.	Typ.	Max.	Units
Propagation delay time L to H, T_{PLH}	$V_{ID}=-1.5V$ to $1.5V, C_{L}=15pF$		70	155	ns
Propagation delay time H to L, T_{PHL}			72	135	ns

RECEIVER FUNCTION TABLE

Differential inputs A-B	RXOUT
$V_{ID} \geq 0.2V$	High level
$-0.2V < V_{ID} < +0.2V$	Undefined
$V_{ID} \leq -0.2V$	Low level

ISOLATION CHARACTERISTICS

Parameter	Conditions	Min.	Typ.	Max.	Units
Isolation test voltage	Flash tested for 1 second	1000			Vrms

ABSOLUTE MAXIMUM RATINGS

Supply voltage V_{CC} with respect to pin 11	7V
Input voltage Dx ENABLE and D inputs	7V
Input voltage range, receiver A or B inputs	-25V to +25V
Receiver differential input voltage range	-25V to +25V
Output voltage range, driver	-10V to +15V
Power dissipation	2000mW
Isolation capacitance	40pF
Isolation voltage (flash tested for 1 second)	1000Vrms
Data transmission rate	1.25Mbps
Lead temperature 1.5mm from case for 10 seconds	300°C

All data taken at $T_A=25^\circ C, V_{CC}=5V$.

EACH DRIVER ELECTRICAL CHARACTERISTICS					
Parameter	Test conditions	Min.	Typ.	Max.	Units
High level output voltage, V_{OH}	$I_{OH}=-33\text{mA}$		3.7		V
Low level output voltage, V_{OL}	$I_{OH}=33\text{mA}$		1.1		V
Differential output voltage, V_{OD1}	$I_O=0$	1.5		6.0	V
Differential output voltage, V_{OD2}	$R_L=100\Omega$	2.0			V
	$R_L=54\Omega$	1.5		5.0	V
Change in magnitude of differential output voltage, ΔV_{OD}	$R_L=54\Omega$ or 100Ω			± 0.2	V
Common mode output voltage, ΔV_{OC}		-1.0		3.0	V
Change in magnitude of common mode output voltage, ΔV_{OC}					± 0.2
Output current power off, I_O	$V_{CC}=0$, $V_O=-7.0\text{V}$ to 12V			± 100	μA
High level input current, I_{IH}	$V_{IH}=4.0\text{V}$		2.0	20	μA
Low level input current, I_{IL}	$V_{IL}=0.8\text{V}$			-15	mA
Short circuit output current, I_{OS}	$V_O=-7.0\text{V}^1$			-250	mA
	$V_O=12\text{V}^1$			250	mA

DRIVER SWITCHING CHARACTERISTICS					
Parameter	Test conditions	Min.	Typ.	Max.	Units
Differential output delay time, T_{DD}	$R_L=54\Omega$, $CL=50\text{pF}$		20	25	ns
Output disable time from high level, T_{PHZ}	$R_L=110\Omega$, $CL=50\text{pF}$		90	120	ns
Output disable time from low level, T_{PLZ}	$R_L=110\Omega$, $CL=50\text{pF}$		30	45	ns
Propagation delay time L to H, T_{PLH}	$R_L=27\Omega$, $CL=50\text{pF}$		70	145	ns
Propagation delay time H to L, T_{PHL}			70	145	ns
Differential output transition time, T_{TD}	$R_L=54\Omega$, $CL=50\text{pF}$		150	300	ns
Output enable time to high level, T_{PZH}	$R_L=110\Omega$, $CL=50\text{pF}$		80	120	ns
Output enable time to low level, T_{PZL}	$R_L=110\Omega$, $CL=50\text{pF}$		40	60	ns

DRIVER FUNCTION TABLE			
DX_{IN}	D_X ENABLE	DX_Y Output	DX_Z Output
High level	High level	High level	Low level
Low level	High level	Low level	High level
Irrelevant	Low level	High impedance	High impedance

TEMPERATURE CHARACTERISTICS				
Parameter	Min.	Typ.	Max.	Units
Operating free-air temperature range	0		60	$^{\circ}\text{C}$
Storage temperature range	-40		125	$^{\circ}\text{C}$

1. Duration of short circuit should not exceed 1 second.

APPLICATION NOTES

The EIA-485 standard is an upgrade version of the EIA RS-422 standard. The use of balanced data transmission lines in distributing data to several systems components and peripherals over relatively long lines, requires the use of multiple driver/receiver combinations on a single twisted pair line. This is referred to as a party-line (see figure 1).

The NM485DC is an isolated interface device providing EIA-485 compatibility. A single supply provides all necessary power for the device, either side of the isolation boundary. The isolation feature allows the logic and differential grounds to be isolated from each other, eliminating ground loop current and inherently long noise paths.

The maximum number of drivers and receivers that may be placed on a single communication bus depends upon their loading characteristics, relative to the definition of a Unit Load (U.L.), transmission speed does not affect the unit load capability. As the NM485DC complies with the EIA-485 standard a maximum of 32 unit loads per line is recommended. A unit load usually consists of a driver-receiver pair, but not the line termination resistors.

With only a 5V supply connected, the NM485DC receiver and differential outputs give levels greater than +2.7V and ±1.5V respectively. This known output state may be used as a reference for use in environments with considerable levels of noise. An unused driver should be disabled by grounding its enable pin to reduce power dissipation.

Figure 2 illustrates the way one receiver and one driver of the NM485DC may be connected to implement an isolated EIA-485 interface with a typical UART and processor bus. Figure 3 demonstrates how the NM485DC may be used as a transceiver. This is possible by using the driver enable to determine the data direction. For example, the device could receive when the driver enable is low and transmit when it is high.

Precise circuitry will depend on the application and in particular the use of the control lines shown will need to be altered to suit the situation. For instance the maximum synchronous baud rate of the 8251A is 64kbps, whereas the NM485DC had a maximum baud rate of 1.25Mbps.

Implementing an isolated LONWORKS (™) network using the NM485DC

The Echleon LONWORKS (Local Operating Network) network is designed to be used in industrial applications in which other electrical equipment is operated. Often the LON (®) will be the method of controlling machinery or sensing machine activity. The environment is therefore likely to be electrically noisy and to reduce the possibility of data corruption, an isolated network communications system is a preferred method of data transfer.

The EIA-485 standard provides a method of achieving multi-point (multi-drop) data transmission over balanced twisted pair transmission lines. The standard is a differential scheme offering a large degree of common mode immunity compared to single ended schemes. The isolated differential method offers the highest common mode and line noise immunity for wire based systems.

The NM485DC is a fully isolated EIA-485 standard dual driver and receiver, which requires only a single 5V supply. The device offers full data direction programming and can hence be configured as a transceiver. The NM485DC can be operated at transmitting or receiving data rates of up to 1.25Mbps, hence is fully compatible with the LONTALK (™) transmission rate standards.

Configuring the NM485D as a transceiver

The NM485D is configured as a transceiver simply by connecting the inverting R1_B receive to the inverting D1_Z drive and the non-inverting R1_A receive to the non-inverting D1_Y drive, similarly R2_B to D2_Z and R2_A to D2_Y for the second transceiver (see figure 3), in this way the NM485D is configured as a dual transceiver. The data direction is determined by the driver enable pins (D_x ENABLE), the transceiver acting as a transmitter when the enable pin is high and a receiver when the enable pin is low.

If only a single transceiver is required it is recommended that the second transceiver driver is disabled, this reduces the power consumption to around 0.6W. The second driver is disabled by taking the driver enable pin low, this should be via a pull-down resistor (recommend value is 1KΩ).

Figure 1

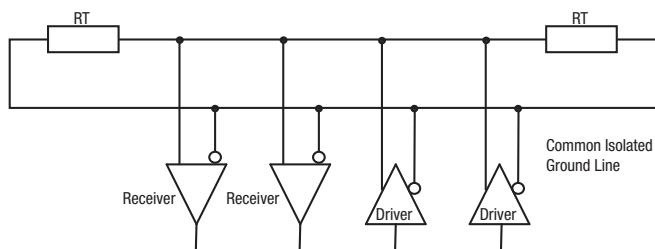

Figure 2

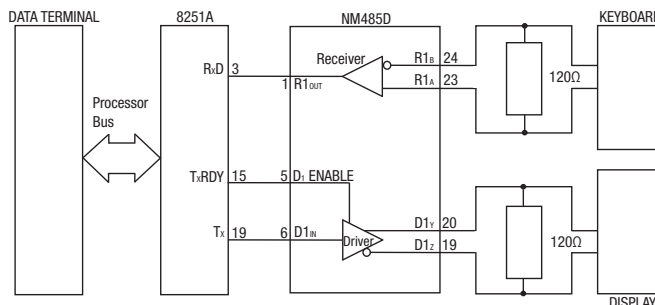
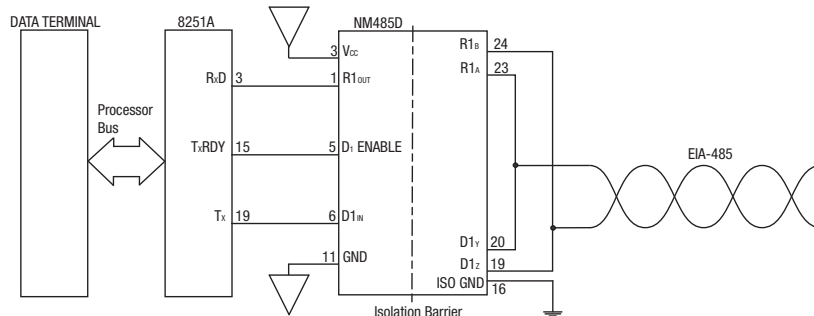

Figure 3



APPLICATION NOTES (continued)

System Performance

The EIA-485 standard allows a maximum of 32 unit loads to be connected to the network, this is less than the LONWORKS standard of 64 nodes. A unit load is any single driver, receiver or transceiver in the EIA-485 standard, or any single node under the LONWORKS scheme. Similarly the EIA-485 standard specifies a maximum data rate standard of 10Mbps, whereas the maximum LONWORKS data rate standard is 1.25Mbps. The resultant maximum system performance for the LONWORKS EIA-485 configuration is therefore 32 nodes at 1.25Mbps. The NM485D isolated serial interface devices supports this configuration, as well as any lower specified system.

The EIA-485 standard defines the maximum line length as a function of data rate (in Mbps). This implies that the user must choose between the line length of the network and its maximum data transmission rate.

The isolated interface has been used in previous configurations (e.g. NM232D) to increase the available line length as isolated data lines are much less susceptible to ground currents and variations in local supplies. The feature of isolation in a LON environment is intended to be used primarily to improve noise susceptibility, therefore, unless the line length improvements can be reliably demonstrated by the user, the EIA-485 recommendations on maximum cable length are assumed to apply.

The complete hardware implementation for the LONWORKS EIA-485 network is relatively simple and straight forward (see figure 5). There is a minimum of components required, only 1 interface part and one resistor, and the complete LONTALK transmission protocols are supported. The isolation barrier of 1000Vrms offers improved noise immunity compared to a non-isolated system and eliminates node-to-node supply voltage mismatch and possible ground current loops.

If protection from voltage transients is required, then a bi-directional TransZorb from each line side to ground should be connected (see figure 6). A TransZorb with a breakdown voltage higher than the common-mode voltage required should be used. However the added parasitic capacitance will load down the bus, and should therefore be taken into consideration.

Figure 4

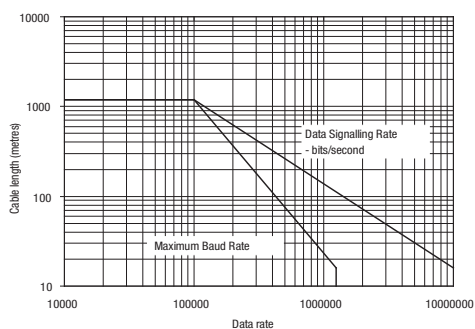

Figure 5

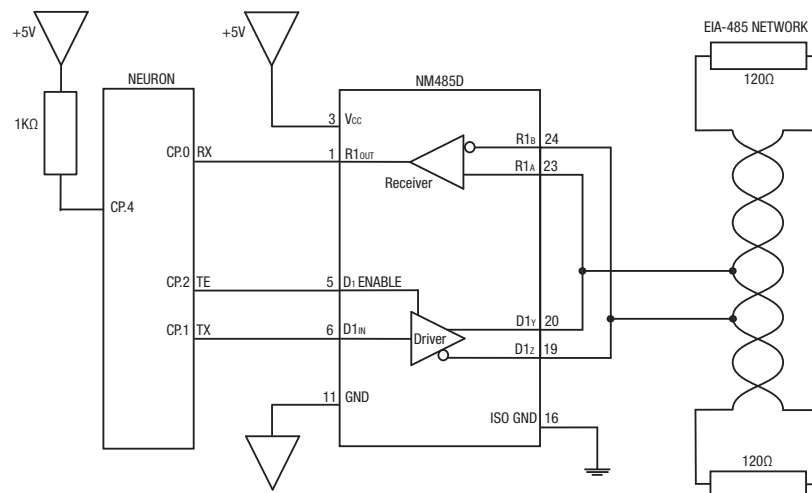
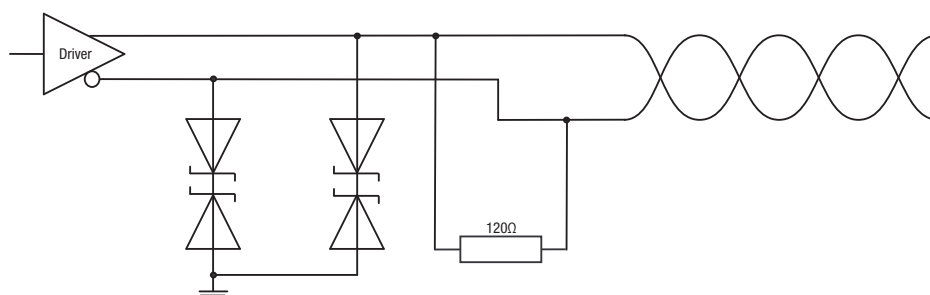

Figure 6



APPLICATION NOTES (continued)

NM485D receiver output status

The receiver output will be high (>2.7V) when the differential input lines are left open (open circuit). However, when a line termination resistor is attached, the inputs are effectively shorted together, not left floating. Since the receiver has typically 70mV of hysteresis, the output will remain in its last active state, high or low.

To force the receiver output to a known state, the configuration shown in figure 7 should be used. It should be noted that this arrangement will use typically 100mW of power, for each receiver connected in this manner.

The termination resistors are used to generate a DC bias, which forces the receiver into a high state, when no signal is applied. This arrangement will still allow the output to switch due to a change at the input, whilst maintaining line termination characteristics.

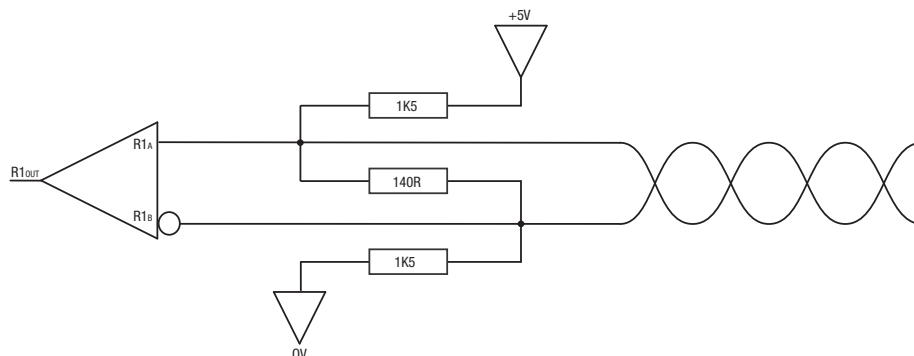

TECHNICAL NOTES

ISOLATION VOLTAGE

'Hi Pot Test', 'Flash Tested', 'Withstand Voltage', 'Proof Voltage', 'Dielectric Withstand Voltage' & 'Isolation Test Voltage' are all terms that relate to the same thing, a test voltage, applied for a specified time, across a component designed to provide electrical isolation, to verify the integrity of that isolation.

Murata Power Solutions NM485DC series of DC/DC converters are all 100% production tested at their stated isolation voltage. This is 1000Vrms for 1 second.

A question commonly asked is, "What is the continuous voltage that can be applied across the part in normal operation?"

For a part holding no specific agency approvals, such as the NM485DC series, both input and output should normally be maintained within SELV limits i.e. less than 42.4V peak, or 60VDC. The isolation test voltage represents a measure of immunity to transient voltages and the part should never be used as an element of a safety isolation system. The part could be expected to function correctly with several hundred volts offset applied continuously across the isolation barrier; but then the circuitry on both sides of the barrier must be regarded as operating at an unsafe voltage and further isolation/insulation systems must form a barrier between these circuits and any user-accessible circuitry according to safety standard requirements.

REPEATED HIGH-VOLTAGE ISOLATION TESTING

It is well known that repeated high-voltage isolation testing of a barrier component can actually degrade isolation capability, to a lesser or greater degree depending on materials, construction and environment. The NM485DC series has toroidal isolation transformers, with no additional insulation between primary and secondary windings of enameled wire. While parts can be expected to withstand several times the stated test voltage, the isolation capability does depend on the wire insulation. Any material, including this enamel (typically polyurethane) is susceptible to eventual chemical degradation when subject to very high applied voltages thus implying that the number of tests should be strictly limited. We therefore strongly advise against repeated high voltage isolation testing, but if it is absolutely required, that the voltage be reduced by 20% from specified test voltage.

This consideration equally applies to agency recognized parts rated for better than functional isolation where the wire enamel insulation is always supplemented by a further insulation system of physical spacing or barriers.

RoHS COMPLIANCE INFORMATION



This series is compatible with RoHS soldering systems with a peak wave solder temperature of 300°C for 10 seconds. The pin termination finish on this product series is Matte Tin over Nickel Preplate. The series is backward compatible with Sn/Pb soldering systems.

For further information, please visit www.murata-ps.com/rohs

PACKAGE SPECIFICATIONS

MECHANICAL DIMENSIONS

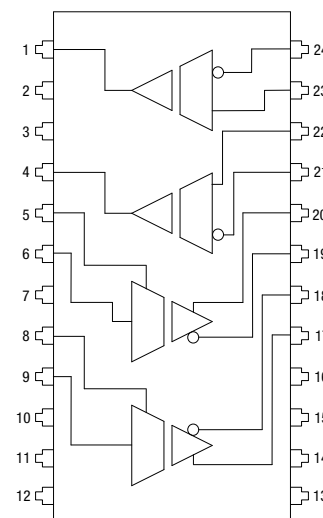
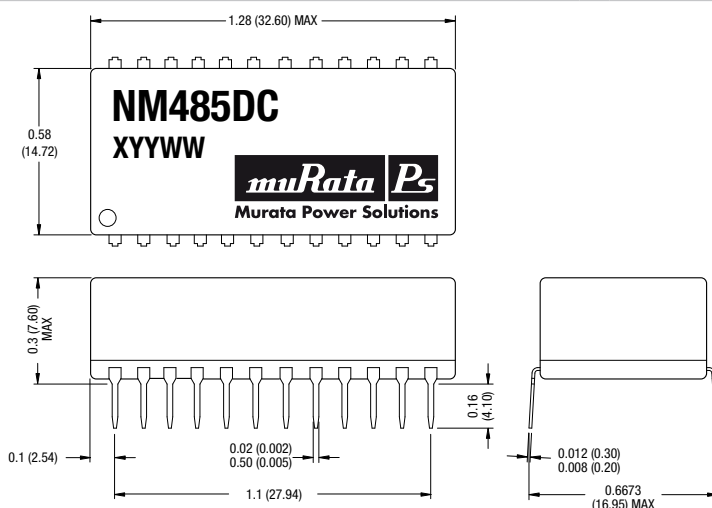

Weight: 5.9g
 All pins on a 0.1 (2.54) pitch.
 All dimensions are in inches (mm) ±0.01 (0.25).

PIN CONNECTIONS

Pin	Function	Description
1	R1 _{OUT}	Receiver number 1 output TTL logic
2	NC	No internal connection
3	V _{CC}	+5V supply
4	R2 _{OUT}	Receiver number 2 output TTL logic
5	D ₁ ENABLE	Driver no.1 ENABLE
6	D ₁ IN	Driver no.1 input TTL logic
7	NC	No Internal Connection
8	D ₂ ENABLE	Driver number 2 ENABLE
9	D ₂ IN	Driver number 2 input TTL logic
10	NC	No Internal Connection
11	GND	Ground
12-15	NC	No Internal Connection
16	ISO GND	Isolated ground
17	D ₂ y	Driver number 2 differential non-inverting output
18	D ₂ z	Driver number 2 differential output
19	D ₁ z	Driver number 1 differential inverting output
20	D ₁ y	Driver number 1 differential non-inverting output
21	R ₂ B	Receiver number 2 differential inverting input
22	R ₂ A	Receiver number 2 differential non-inverting input
23	R ₁ A	Receiver number 1 differential non-inverting input
24	R ₁ B	Receiver number 1 differential inverting input

RECOMMENDED FOOTPRINT

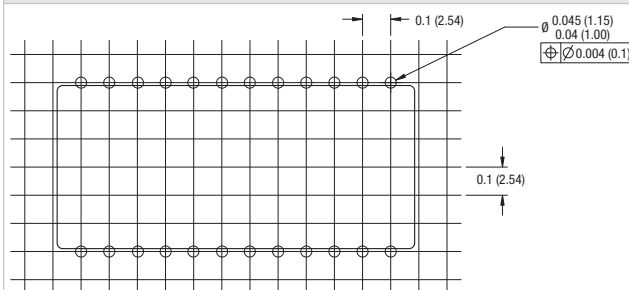

All dimensions are in inches (mm) ±0.01 (0.25)

TUBE OUTLINE DIMENSIONS

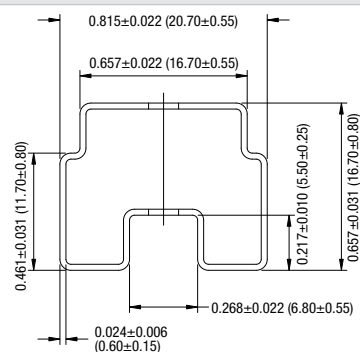

All dimensions are in inches (mm) ±0.01 (0.25)

Tube Quantity : 15

